

Floodlight PRO TSG 100W-150W-200W Philips Driver
Projecteur PRO TSG 100W-150W-200W Philips Driver

TSONG

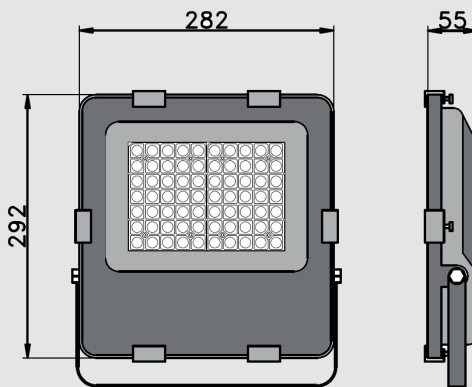

100 Watt



15000 Lm
EFF150
IP66



PHILIPS
DRIVER



Technical Specifications

Données techniques

100 Watt



Input Voltage	Max. Current	Operating Voltage	Constant Current	Power Consumption	Power Factor
AC200-240V	0.5A	DC84V	1.05A	100W	> 0.95
LED Type	LED Q'ty	CRI			
SMD2835	140 PCS	> 80Ra			
Life Time	Certifications	IP Code	Luminaire Class	Product Dimension	N.W.
50.000 Hours	CE, Rohs	IP66	Class I	L282*W55*H292mm	3.0Kg
Operating Temperature	Humidity Operating	Driver / Transfo			Packing Dimension
-20°C to +55°C	10-80% RH	Philips Xitanium			L328*W70*H363mm
Outer carton package	5*1 layer = 5PCS/carton, L370*W345*H380mm, GW 17 Kg				

LUMINOUS FLUX

100 Watt

CCT	3000K	4000K	6000K
Luminous Efficiency	140 Lm/W	150 Lm/W	150 Lm/W
Luminous Flux	14000 Lm	15000 Lm	15000 Lm
Beam Angle	90°		



PROFESSIONAL APPLICATIONS

TSG910 IP66

Page 1/4



Floodlight PRO TSG 100W-150W-200W Philips Driver
Projecteur PRO TSG 100W-150W-200W Philips Driver

TSONG



150 Watt

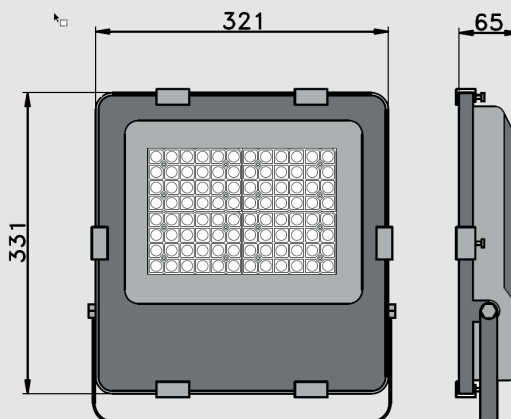

22500 Lm

EFF150

IP66



PHILIPS
DRIVER



Technical Specifications

Données techniques

150 Watt



Input Voltage	Max. Current	Operating Voltage	Constant Current	Power Consumption	Power Factor
AC200-240V	0.75A	DC132V	1.05A	150W	> 0.95
LED Type	LED Q'ty	CRI			
SMD2835	192 PCS	> 80Ra			
Life Time	Certifications	IP Code	Luminaire Class	Product Dimension	N.W.
50.000 Hours	CE, Rohs	IP66	Class I	L321*W65*H331mm	3.7Kg
Operating Temperature	Humidity Operating	Driver / Transfo			Packing Dimension
-20°C to +55°C	10-80% RH	Philips Xitanium			L368*W80*H410mm
Outer carton package	5*1 layer = 5PCS/carton, L420*W385*H425mm, GW 20.5 Kg				

LUMINOUS FLUX FLUX LUMINEUX

150 Watt

CCT	3000K	4000K	6000K
Luminous Efficiency	140 Lm/W	150 Lm/W	150 Lm/W
Luminous Flux	21000 Lm	22500 Lm	22500 Lm
Beam Angle	90°		



PROFESSIONAL APPLICATIONS

TSG910 IP66

Page 2/4



Floodlight PRO TSG 100W-150W-200W Philips Driver
Projecteur PRO TSG 100W-150W-200W Philips Driver

TSONG



200 Watt

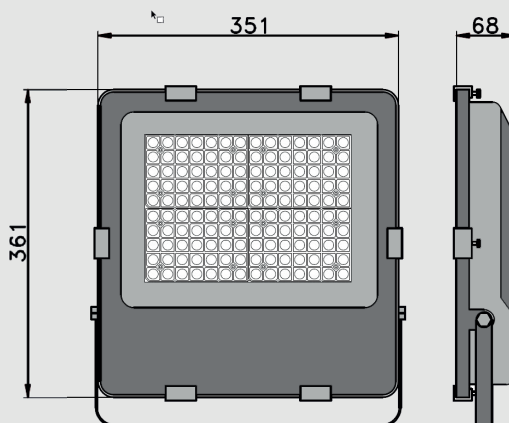

30000 Lm
EFF150
IP66



PHILIPS
DRIVER



Technical Specifications
Données techniques

200 Watt



Input Voltage	Max. Current	Operating Voltage	Constant Current	Power Consumption	Power Factor
AC200-240V	1.00A	DC168V	1.05A	200W	> 0.95
LED Type	LED Q'ty	CRI			
SMD2835	280 PCS	> 80Ra			
Life Time	Certifications	IP Code	Luminaire Class	Product Dimension	N.W.
50.000 Hours	CE, Rohs	IP66	Class I	L351*W68*H361mm	4.9Kg
Operating Temperature	Humidity Operating	Driver / Transfo			Packing Dimension
-20°C to +55°C	10-80% RH	Philips Xitanium			L398*W83*H435mm
Outer carton package	4*1 layer = 4PCS/carton, L415*W350*H435mm, GW 21.6 Kg				

LUMINOUS FLUX
FLUX LUMINEUX

200 Watt

CCT	3000K	4000K	6000K
Luminous Efficiency	140 Lm/W	150 Lm/W	150 Lm/W
Luminous Flux	28000 Lm	30000 Lm	30000 Lm
Beam Angle	90°		



PROFESSIONAL APPLICATIONS

TSG910 IP66



Floodlight PRO TSG 100W-150W-200W Philips Driver
Projecteur PRO TSG 100W-150W-200W Philips Driver

TSONG



Kelvin range / Kelvin disponible

- 3000K** Warmwhite / Blanc chaud
- 4000K** Neutralwhite / Blanc neutre
- 5000K** Coldwhite / Blanc froid



Packaging / Emballage

- 100 Watt**
- Weight - Poids 1 pce | 3.0Kg**
- 5 pcs / box - carton | 17.0Kg**

- 150 Watt**
- Weight - Poids 1 pce | 3.7Kg**
- 5 pcs / box - carton | 20.5Kg**

- 200 Watt**
- Weight - Poids 1 pce | 4.9Kg**
- 4 pcs / box - carton | 21.6Kg**



Product Images / Photos supplémentaires



Product Code(s) / Codes d'articles

TSG910030	LED Floodlight 100W 3000K 14000Lm PHILIPS XITANIUM DRIVER 230v IP66
TSG910040	LED Floodlight 100W 4000K 15000Lm PHILIPS XITANIUM DRIVER 230v IP66
TSG910060	LED Floodlight 100W 6000K 15000Lm PHILIPS XITANIUM DRIVER 230v IP66
TSG910130	LED Floodlight 150W 3000K 21000Lm PHILIPS XITANIUM DRIVER 230v IP66
TSG910140	LED Floodlight 150W 4000K 22500Lm PHILIPS XITANIUM DRIVER 230v IP66
TSG910160	LED Floodlight 150W 6000K 22500Lm PHILIPS XITANIUM DRIVER 230v IP66
TSG910230	LED Floodlight 200W 3000K 28500Lm PHILIPS XITANIUM DRIVER 230v IP66
TSG910240	LED Floodlight 200W 4000K 30000Lm PHILIPS XITANIUM DRIVER 230v IP66
TSG910250	LED Floodlight 200W 6000K 30000Lm PHILIPS XITANIUM DRIVER 230v IP66

PROFESSIONAL APPLICATIONS

TSG910 IP66

Page 4/4

